

PRODUCTS & PARTS

2019-20





Welcome to the FLEX Generation

The modern design of the FLEX makes a bold statement, and the DUO conditioning system under the lid backs it up. DUO Technology gives you the benefit of easily using more than one lane conditioner in your center. By combining the precise accuracy of Sanction Technology™ with dual conditioner cartridges, and still being able to verify how much conditioner will be applied to the lane, DUO Technology gives you versatility, dependability, and accountability.

FLEX gives you features to improve performance, simplify your experience, and allows you to have more control of your lane maintenance program. Want even more? Choose from any of our upgrades for a machine perfectly customized to fit your needs.

FLEX WALKER



17-5803
(115V/60 Hz)
17-5853
(230V/50 Hz)

FLEX



17-5707
(115V/60 Hz)
17-5757
(230V/50 Hz)

FLEX Machine Weight: 331 lbs. (150.1 kg)

FLEX Walker Machine Weight: 370 lbs. (167.8 kg)

CONDITIONING

- Uses Sanction Technology™ to measure conditioner volume before applying to lane
- Variable Speed Buffer option (see upgrades)
- DUO conditioning system (two pumps and two conditioner cartridges)
- DUO transfer system
- Two pre-filled/refillable conditioner cartridges
- Alternate two conditioners in one pass
- Adjustable microliter streams (per load setting)
- Ability to condition each lane in less than 90 seconds
- Conditioner float switches with low level warning message
- Board-to-board pattern control
- "Oil Only" function
- Touchscreen control of oil pump calibration

CLEANING

- Cleaner Mixing System option (see upgrades)
- Squeegee cartridge for easy replacement of blades
- Sprayless cleaning system
- Ability to monitor and adjust cleaner output
- Cleaner float switches with low level warning message
- Large waste recovery tank (50+ lanes before emptying)
- Duster/cleaning cloth waste roll on top for easy removal
- Patented cushion roller wrap for better cleaning
- Super quiet DC vacuum motor
- "Clean Only" function
- "Dust Only" function
- Touchscreen control of cleaner pump calibration

DRIVE

- Patented six variable drive speeds
- Independent adjustable cleaning speed
- Self-adjusting drive speeds
- LED arrow for better operator positioning
- Dual Drive System

TOUCHSCREEN/PLC

- Full color 7" touchscreen display
- Three programs for both AM and PM
- Stores 30 programs in memory
- Test input/output menu option
- Full detailed error messages

BATTERIES

- Single lightweight lithium battery
- Three battery options based on number of lanes conditioned per day
- External battery charger

SPECIAL FEATURES

- Pin Deck Treatment Spray System option (see upgrades)
- Easy sliding detachable lid assembly
- KOSI™ software kit included (Kegel Online Support Interface)

WALKER ONLY FEATURES

- Zero Turn Radius lane to lane walking function
- Auto-aligning lane whiskers
- Smart processor auto-align memory
- Object detection
- Automatic burn pair



FLEX BONUS WARRANTY

Receive an 18 month warranty with an additional 18 months if you agree to only use Kegel lane maintenance products in your lane machine.

UPGRADES

Pin Deck Treatment System

164-8202

- Insert Spot On Pin Deck Spray directly in your lane machine for simple application

Cleaner Mixing System*

- Self-mixing cleaner adjustments
- Precise mixing ratios

Variable Speed Buffer*

- Ability to customize four preset buffer speeds
- More control of front to back taper

Batteries

- Each machine comes with our K2 Energy® lithium battery
- Upgrade to larger battery based on number of lanes conditioned per day



158-1634**
(40 lanes)



158-1634BU
(62 lanes)



158-1634CU
(90 lanes)

* Factory upgrade (must be installed at time of purchase).

** All FLEX Machines come standard with battery 158-1634.

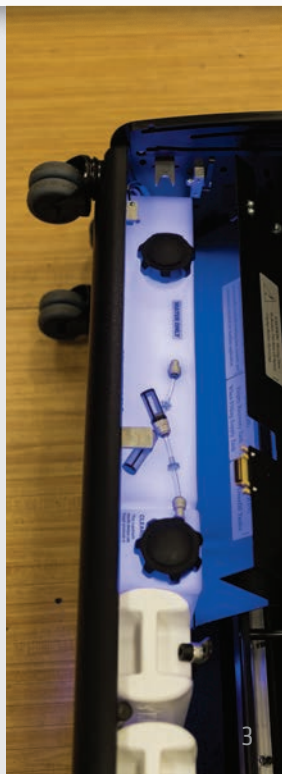



IKON™

High Tech Made Easy

IKON is a battery powered combination lane machine that incorporates Kegel's proven technology with the modern styling of the FLEX.

The IKON uses Sanction Technology™ for the conditioning system which is reliable, verifiable, and accurate to $\pm 1\%$ with continued precision of $\pm 0.5\%$ after millions of cycles.

For cleaning, the IKON utilizes a sprayless system, which cleans the lane without any overspray into the gutters, keeping your customers and pinsetters cleaner.

Kegel's patented conditioning and cleaner systems are the only ones that can be checked and verified before you begin lane maintenance - now that's peace of mind.



FEATURES

- Sanction Technology™ Conditioning System with forward and reverse capabilities
- DUO Transfer System enhances the smoothness of the pattern and allows for easy pattern changes
- Patented sprayless cleaning system
- Full color 3.5" touchscreen display
- PLC stores 15 patterns in memory
- Choose from 3 different size lithium batteries based on your bowling center's needs or number of lanes conditioned per day
- Conditions each lane in less than 90 seconds

TECHNICAL SPECIFICATIONS

- Part Number:
17-5900 (115V/60 Hz)
17-5950 (230V/50 Hz)
- Weight without the battery: 330 lbs (149.7 Kg)
- Battery Specifications
158-1634 (Red) 25.6 Ah | 24 lbs (10.8 Kg) - Standard
158-1634BU (Orange) 38.4 Ah | 29 lbs (13.1 Kg) - Upgrade
158-1634CU (Yellow) 51.2 Ah | 39 lbs (17.6 Kg) - Upgrade



IKON BONUS WARRANTY

Receive an 18 month warranty with an additional 18 months if you agree to only use Kegel lane maintenance products in your lane machine.



Affordable Quality



The Crossfire is a compact, durable and highly functional lane machine at a very affordable price. This wick combination lane machine allows small centers to experience high quality lane maintenance only Kegel can deliver.

Features:

- Cleans and conditions the lane in about 80 seconds
- On-board keypad for simple machine programming
- 6 High-Flow Wick Pads (upgradeable to 8)
- 12 Lane Conditioner Capacity (upgradeable to 60)
- 32 Lane Cleaner Capacity
- 3 Drive Speeds for enhanced pattern taper
- Compact Design

Machine Weight: 275 lbs. (124.7 kg)

Part Number:

Crossfire - 6 PAD MODEL C
17-5200C (115V/60 Hz) 6 PAD/CAM MACHINE
17-5250C (230V/50 Hz) 6 PAD/CAM MACHINE

Optional Upgrade Kit

Increase to 8 Wick Pads and Conditioner Capacity to 60 lanes
158-8241 - CROSSFIRE UPGRADE KIT - 115V
158-8241E - CROSSFIRE UPGRADE KIT - 230V

Lane Machine Assist

One person can quickly and easily raise and lower their lane machine safely.

Physical Properties:

- Color: Black
- Dimensions: Width: 60" | Height: 8" | Depth: 8"
- Lifting Capacity: Any Kegel Lane Machine
- Packaging: Assembled and ready to mount

Part Number: 154-8510

(Must be installed by a qualified contractor.)

Bracket Kit for all models

Part Number: 154-8520

Replacement Strap Kit

Part Number: 154-8519

LANE MACHINE COMPARISON CHART

	FLEX WALKER	FLEX	IKON
CONDITIONING			
Sanction Technology™ fluid metering conditioning system	✘	✘	✘
Conditions each lane in less than 90 seconds	✘	✘	✘
Conditioner float switches with low level warning message	✘	✘	✘
Left-Right pattern control	✘	✘	✘
"Oil Only" function	✘	✘	✘
Touchscreen control of microliter stream	✘	✘	
Touchscreen control of oil pump calibration	✘	✘	
DVO conditioning system (two pumps and two conditioner cartridges)	✘	✘	
DVO transfer system (roller and single transfer brush)	✘	✘	✘
Two pre-filled/refillable conditioner cartridges	✘	✘	
Ability to alternate two conditioners in one pass	✘	✘	
Board-to-board pattern control	✘	✘	✘
Measure conditioner volume per board stream before applying to lane	✘	✘	✘
Adjustable microliter streams (per load setting)	✘	✘	
Different conditioners in each cartridge	✘	✘	
4 Variable Buffer speeds	OPTIONAL	OPTIONAL	
CLEANING			
Sprayless cleaning system	✘	✘	✘
Ability to monitor and adjust cleaner output to the milliliter	✘	✘	✘
Cleaner float switches with low level warning message	✘	✘	✘
Large waste recovery tank (50+ lanes before emptying)	✘	✘	✘
Duster/Cleaning cloth waste roll on top for easy removal	✘	✘	✘
Patented cushion roller wrap for better cleaning	✘	✘	✘
Ultra quiet DC vacuum motor	✘	✘	✘
"Clean Only" function	✘	✘	✘
"Dust Only" function	✘	✘	✘
Adjustable "End Cleaning" and "Return" distance	✘	✘	✘
Multi-adjustment squeegee assembly	✘	✘	✘
Touchscreen control of cleaner volume	✘	✘	✘
Squeegee cartridge for easy replacement of blades	✘	✘	✘
Touchscreen control of cleaner pump calibration	✘	✘	
Cleaner supply tank with large opening for filling	✘	✘	✘
Recovery tank with handles for better transporting/emptying	✘	✘	✘
Self-mixing cleaner system	OPTIONAL	OPTIONAL	
DRIVE			
Patented six variable drive speeds	✘	✘	✘
Independent adjustable cleaning speed	✘	✘	✘
Self-adjusting drive speeds	✘	✘	✘
Zero Turn Radius lane to lane walking function	✘		
Auto-aligning lane whiskers	✘		
Smart processor auto-align memory	✘		
Object detection	✘		
LED arrow for better operator positioning	✘	✘	
KEYPAD/PLC			
Full Color 3.5" touchscreen display			✘
Full Color 7" touchscreen display	✘	✘	
One program for AM and PM			✘
Three programs for AM and PM	✘	✘	
Automatic burn pair	✘	✘	
Stores 15 programs in memory			✘
Stores 30 programs in memory	✘	✘	
Test input/output menu option	✘	✘	✘
Error messages displayed			✘
Full detailed error messages	✘	✘	
BATTERIES			
Single lightweight lithium battery	✘	✘	✘
External battery charger	✘	✘	✘
3 lithium battery options based on number of lanes conditioned per day	✘	✘	✘
SPECIAL FEATURES			
KOSI™ software kit included (Kegel Online Support Interface)	✘	✘	✘
Wi-Fi Connectivity Kit	✘	✘	✘
Pin Deck treatment spray system	OPTIONAL	OPTIONAL	

Lane Conditioners

SANCTION® CONDITIONERS

Whether you want more hook, less hook, or something in-between, the perfect lane conditioner is up to you



CURRENT™

- Viscosity: 52.0 cps.
- Surface Tension: 23.3 dyn/cm
- Shipping Weight: 40 lbs. (18.1 kg)
- One Container: 1.25 gallon (4.73 liters)
- Packaging: 4 containers per case
5 gallons (19 liters)

Part Number: 156-8175



TERRAIN™

- Viscosity: 81.0 cps.
- Surface Tension: 33.3 dyn/cm
- Shipping Weight: 40 lbs. (18.1 kg)
- One Container: 1.25 gallon (4.73 liters)
- Packaging: 4 containers per case
5 gallons (19 liters)

Part Number: 156-8185



- Shipping Weight: 38.5 lbs. (17.4 kg)
- One cartridge: 0.4 gallons (1.5 liters)
- Packaging: 12 cartridges per case
4.75 gallons (18 liters)

Part Number: 156-8175C



- Shipping Weight: 38.5 lbs. (17.4 kg)
- One cartridge: 0.4 gallons (1.5 liters)
- Packaging: 12 cartridges per case
4.75 gallons (18 liters)

Part Number: 156-8185C



FIRE™

- Viscosity: 45.1 cps.
- Surface Tension: 23.6 dyn/cm
- Shipping Weight: 40 lbs. (18.1 kg)
- One Container: 1.25 gallon (4.73 liters)
- Packaging: 4 containers per case
5 gallons (19 liters)

Part Number: 156-8135



ICE™

- Viscosity: 40.9 cps.
- Surface Tension: 23.2 dyn/cm
- Shipping Weight: 40 lbs. (18.1 kg)
- One Container: 1.25 gallon (4.73 liters)
- Packaging: 4 containers per case
5 gallons (19 liters)

Part Number: 156-8130



- Shipping Weight: 38.5 lbs. (17.4 kg)
- One cartridge: 0.4 gallons (1.5 liters)
- Packaging: 12 cartridges per case
4.75 gallons (18 liters)

Part Number: 156-8135C



- Shipping Weight: 38.5 lbs. (17.4 kg)
- One cartridge: 0.4 gallons (1.5 liters)
- Packaging: 12 cartridges per case
4.75 gallons (18 liters)

Part Number: 156-8130C

Lane Conditioners

SANCTION® CONDITIONERS



CURVE™ LANE CONDITIONER

- Viscosity: 41.0 cps.
- Surface Tension: 22.0 dyn/cm
- Shipping Weight: 40 lbs. (18.1 kg)
- One Container: 1.25 gallon (4.73 liters)
- Packaging: 4 containers per case 5 gallons (19 liters)

Part Number: 156-8145



- Shipping Weight: 38.5 lbs. (17.4 kg)
- One cartridge: 0.4 gallons (1.5 liters)
- Packaging: 12 cartridges per case 4.75 gallons (18 liters)

Part Number: 156-8145C



INFINITY™ LANE CONDITIONER

- Viscosity: 36.5 cps.
- Surface Tension: 23.1 dyn/cm.
- Shipping Weight: 40 lbs. (18.1 kg)
- One Container: 1.25 gallon (4.73 liters)
- Packaging: 4 containers per case 5 gallons (19 liters)

Part Number: 156-8115



DEFENSE-S®

- Viscosity: 47.3 cps.
- Surface Tension: 22.7 dyn/cm.
- Shipping Weight: 40 lbs. (18.1 kg)
- One Container: 1.25 gallon (4.73 liters)
- Packaging: 4 containers per case 5 gallons (19 liters)

Part Number: 156-8025

WICK-PAD & SANCTION® CONDITIONERS



PRODIGY® LANE CONDITIONER

- Viscosity: 31.2 cps.
- Surface Tension: 23.7 dyn/cm.
- Shipping Weight: 40 lbs. (18.1 kg)
- One Container: 1.25 gallon (4.73 liters)
- Packaging: 4 containers per case 5 gallons (19 liters)

Part Number: 156-8095



NAVIGATE™ LANE CONDITIONER

- Viscosity: 31.3 cps.
- Surface Tension: 23.5 dyn/cm.
- Shipping Weight: 40 lbs. (18.1 kg)
- One Container: 1.25 gallon (4.73 liters)
- Packaging: 4 containers per case 5 gallons (19 liters)

Part Number: 156-8125



- Viscosity: 24.1 cps.
- Surface Tension: 23.6 dyn/cm.
- Shipping Weight: 40 lbs. (18.1 kg)
- One Container: 1.25 gallon (4.73 liters)
- Packaging: 4 containers per case 5 gallons (19 liters)

Part Number: 156-8105

Conditioner Comparison

SANCTION TECHNOLOGY™									
PROPERTIES	TERRAIN	CURRENT	FIRE	ICE	CURVE	NAVIGATE	INFINITY	PRODIGY	DEFENSE-S
VISCOSITY <small>(at 72.5 °F / 22.8 °C)</small>	81	52	45.1	40.9	41	31.3	36.5	31.2	47.3
CHARACTERISTICS									
Lineage (Best for)	Any	Any	League / Tournament	League / Tournament	League	Open Play / League	League / Tournament	Open Play	League
Average Pin Calls	Low/None	Low/None	Low/ Medium	Low/ Medium	Low	Low	Medium	Low/None	High
Cleanability	Moderate	Difficult	Easy	Easy	Moderate	Easy	Moderate	Easy	Difficult
LANE SURFACES									
High Friction Surfaces	Better	Best	Good	Best	Better	Better	Best	Better	Best
Medium Friction Surfaces	Best	Best	Better	Better	Best	Better	Better	Best	Better
Low Friction Surfaces	Best	Better	Best	Good	Better	Better	Good	Best	Good

WICK-PAD TECHNOLOGY			
PROPERTIES	NAVIGATE	PRODIGY	CROSSFIRE
VISCOSITY <small>(at 72.5 °F / 22.8 °C)</small>	31.3	31.2	24.1
WICKING TIME	13 minutes	14 minutes	10 minutes
CHARACTERISTICS			
Lineage (Best for)	Open Play / League	Open Play	Open Play / League
Average Pin Calls	Low	Low	Low
Cleanability	Easy	Easy	Easy
LANE SURFACES			
High Friction Surfaces	Good	Better	Best
Medium Friction Surfaces	Better	Better	Best
Low Friction Surfaces	Better	Best	Good

Lane Cleaners



DEFENSE CX4 S

- Designed for low friction surfaces and stronger backend reaction
- pH: 11.5
- Shipping Weight: 10 lbs. (4.5 kg)
- One Container: 1 Gallon (3.29 liters)
- Packaging: 1 container per case

Part Number: 156-8435



DEFENSE-C®

- pH: 12.6
- Shipping Weight: 46 lbs. (20.8 kg)
- One Container: 2.5 gallons (9.4 liters)
- Packaging: 2 containers per case

Part Number: 156-8405



DEFENSE CX4

- Designed for high friction surfaces
- pH: 12.8
- Shipping Weight: 10 lbs. (4.5 kg)
- One Container: 1 Gallon (3.29 liters)
- Packaging: 1 container per case

Part Number: 156-8425

Cleaner Cloth

EZ Core Technology makes changing cloth "Quick & EZ"! Stop handling dirty cloth and get ultimate cleaning results.

K2 Select Cleaner Cloth

- Color: White
- Roll Dimensions: 43" wide x 20 yards long
- Shipping Weight: 16 lbs. (7.2 kg)
- Packaging: 4 rolls per case

K3 Select Cleaner Cloth

- Color: White
- Roll Dimensions: 43" wide x 30 yards long
- Shipping Weight: 16 lbs. (7.2 kg)
- Packaging: 3 rolls per case
- Compatible with: Kustodian Plus and later model lane machines (Not compatible with Crossfire Lane Machines)

Part Number:

K2 Select (Reusable PVC Core): 153-0047EZ

K3 Select (Reusable PVC Core): 164-0047EZ

K2 Kloth (Cardboard Core): 153-0047P



No-Spill[®] Tank Fill



With No-Spill[®] Tank Fill containers, you can quickly and easily fill your tanks with no mess. Just press the button and the auto-stop feature of the nozzle helps prevent overflowing.

For lane machines with the cleaner mixing system upgrade, use the 2.5 gallon container for water and the 1.25 gallon container for cleaner. For a standard cleaner tank, pre-mix your cleaner in the No-Spill[®] Tank Fill container using the mixing guide on the label.

Part Number:

No-Spill Tank Fill Kit (2.5 & 1.25 Gallons For Cleaner Upgrade Machines) - 164-8661

No-Spill Tank Fill - 2.5 Gallons - 164-8662

No-Spill Tank Fill - 1.25 Gallons - 164-8663

Nozzle For No-Spill Tank Fill - 164-0218

O-Ring For No-Spill Tank Fill Nozzle - 164-0219

Center Care Products



Spot On[™] Pin Deck Spray

Spot On Pin Deck Spray helps you improve pin carry to eliminate off-spot pins and out-of-ranges. Spot On is sold in a spray can to be used in FLEX lane machines with the Pin Deck Treatment Spray System to apply automatically. Or purchase the new gallon size which can be used manually with your favorite spraying device!

- One Can: 14 oz. (0.41 liter)
- Packaging: 4 cans per case

Part Number: 156-8310

- One Container: 1 gallon (3.79 liters)
- Packaging: 1 container per case

Part Number: 156-8311



Balance[™] Approach All-In-One

Balance is the all-in-one solution to maximize the performance of your synthetic approaches. With one product you can create an even and uniform surface for optimal slide conditions. Clean and condition your approaches in one simple application. Use with a rotary buffer.

- One Bottle: 16 oz. (0.47 liters)
- Packaging: 4 bottles per case

Part Number: 156-8320



Microfiber Approach and Utility Mops

Color-coded to separate your approach mops from other mops used in less sensitive areas of your center. These high performance microfiber mops grab dirt and dust for quick and easy cleaning. Approach Mop is ideal for synthetic approaches. Utility Mop is perfect for cleaning in the pit, bowlers area, and elsewhere throughout your center. Machine-washable.



Approach Mop (Green)

- 36" Approach Mop only - 159-4402
- 36" Approach Mop with Handle Assembly - 159-4402C
- 48" Approach Mop only - 159-4403
- 48" Approach Mop with Handle Assembly - 159-4403C



Approach Mop (White)

- 24" Approach Mop only - 159-4420
- 24" Approach Mop with Handle Assembly - 159-4420C
- 36" Approach Mop only - 159-4421
- 36" Approach Mop with Handle Assembly - 159-4421C
- 48" Approach Mop only - 159-4422
- 48" Approach Mop with Handle Assembly - 159-4422C



Utility Mop (Blue)

- 18" Utility Mop only - 159-4410
- 18" Utility Mop with Handle Assembly - 159-4410C
- 24" Utility Mop only - 159-4411
- 24" Utility Mop with Handle Assembly - 159-4411C
- 36" Utility Mop only - 159-4412
- 36" Utility Mop with Handle Assembly - 159-4412C

Industrial Approach Mop



This industrial white approach mop is made of durable non-looped cotton strands that easily lift away dirt and dust. Recommended for wood approaches. Machine-washable.

- 24" Approach Mop only (White) - 159-4430
- 24" Approach Mop with Handle Assembly - 159-4430C
- 36" Approach Mop only (White) - 159-4431
- 36" Approach Mop with Handle Assembly - 159-4431C
- 48" Approach Mop only (White) - 159-4432
- 48" Approach Mop with Handle Assembly - 159-4432C

Gutter Mop



This white gutter mop is made of durable non-looped cotton strands. Recommended for all type gutters. Machine-washable.

- Gutter Mop - 159-4400
- Gutter Mop Frame and Handle only - 159-4400F
- Gutter Mop Complete with Frame and Handle - 159-4400C

Frames and Jaws

- 18" Wire Frame - 159-4450
- 24" Wire Frame - 159-4451
- 36" Wire Frame - 159-4452
- 48" Wire Frame - 159-4453
- Handle Assembly Only - 159-4455

Buffing Pads



Buffing Pad (White)

This 21" buffing pad is made with absorbent synthetic blended yarn. Gently clean away dust from less textured approaches. Machine-washable.

Part Number: 159-4511



Buffing Pad (Green & White)

With green scrubbing stripes on both sides, this 21" buffing pad offers a little something extra. Perfect for more textured approach surfaces, this buffing pad allows you to gently loosen and remove dirt build-up from the pores of your approach. Machine-washable.

Part Number: 159-4510



PIN CLEANING MACHINE & CLEANER CONCENTRATE

- Cleans ALL types of bowling pins
- Includes attachment to sand base of pins
- Weight: 37 pounds (16.7 kg)

Part Number:

17-0040 – 115V/60 Hz

17-0040E – 230V/50 Hz



- Cleans ALL types of bowling pins
- Not harmful to skin
- For use in ALL pin cleaning machines
- One Container: 1 gallon (3.79 liters)
- Packaging: One container per case
- Concentrated cleaner
- pH: 9.2

Part Number: 156-8800



- pH: 8.4
- Easy to use - spray on, wipe off
- Gentle on the skin
- Can be used on ALL bowling balls

Part Number:

156-8768 - 8oz. (0.236 l) bottle

156-8768C - Case (12 - 8oz. bottles)

156-8762 - 32oz. (0.9 l) bottle

Coaching Tools



The Arrow is a 3D Reference Tool that gives players a physical reference point to see when working on a variety of drills. Visualize your set-up position, pushaway, finish position and more!

Arrow - 157-8850



Bowling Ball is not included.

Coaching Tools



SPECTO[®] BOWLING

Specto is a new tracking system for centers, bowlers, and coaches. It records information about bowlers' shots using an advanced sensor and displays it to them on an easy-to-use app. The app also includes game-like modules Worlds and Challenges for practicing.

Specto Complete System - 157-8602 (115v/60Hz)

Specto Complete System - 157-8602E (220v/50Hz)

Calibration Stick - 157-8604



Controller and Protection Guard are not pictured.

TORCH[™] LANE TARGETING LIGHT

The Torch is a patent-pending light targeting tool used to help with accuracy and alignment. Using LED lights, it reflects a path of light on the lane to help you select the correct launch angle and hit your target time after time.

Torch Complete System - 157-8800 (115v/60Hz-220v/50Hz)

Upgrades

Torch 2-Foot & 3-Foot White LED Light Upgrade - 157-8808

Torch Tilt Bar Upgrade - 157-8809

Torch Light Bar Upgrade - 157-8816

Torch Tilt and Light Bar Upgrade - 157-8817

Optional Battery Upgrade - 157-8801

Replacement Parts

Torch Battery Charger Assembly - 157-8805

2 Foot White LED Light (Middle) - 157-8806

3 Foot White LED Light (Top) - 157-8807

4 Foot White LED Light (Bottom) - 157-8802

5 Foot White LED Light (Top) - 157-8803

Power Supply - 157-1805A

Dimmer - 157-1806A

Power Cord (9.8ft DC) - 157-1808

TORCH[™] LANE TARGETING LIGHT

Torch-X Features:

- Multiple light color options
- Tilt bar for precision alignment
- 2-piece top assembly for height adjustments
- Trigger switch flashes light on and off when you hit your target

Torch-X Lane Complete System - 157-8810



LEGEND

SUFFIX	MACHINE	SUFFIX	MACHINE
IKN	IKON	ION	KUSTODIAN ION
FWYEAR*	FLEX WALKER YEAR	XF	CROSSFIRE
FXYEAR*	FLEX YEAR	KP	KUSTODIAN PLUS
FXW	FLEX WALKER 2013-15	KK	KUSTODIAN
FLX	FLEX 2013-15	PX-C	PHOENIX C
KW	KUSTODIAN WALKER		

Some models on the list have been discontinued, making some parts unavailable. Models include Elite (ELT), Standard (STD), Elite Plus (EP), Phoenix (PX), Phoenix-S (PXS)

* YEAR represents the model year in the serial number. Suffix represents all model variations unless model type is specifically indicated (i.e. KP-A).

Cleaning

Recovery Tank - 164-8017 IKN | FXW | FLX
Recovery Tank Filter (for tank 164-8017)
 164-8017F - IKN | FXW | FLX (FLX-17733 / FXW-13229 and ABOVE)

Recovery Tank - 153-8841 - XF
Recovery Tank Filter (for tank 153-8841) - 153-8844 - XF
Recovery Tank - 154-8683 - ION-A | KP-A | KK | PX-C
Folded Recovery Tank Filter (for tank 154-8683) - 154-8684

Recovery Tank - 158-8434 - ION-B | KP-B
Recovery Tank - 158-8617 - KW | ION-C,D
Recovery Tank Filter (for tanks 158-8434, 158-8617) - 158-0406
Recovery Tank Gasket (for tanks 158-8434, 158-8617, 164-8017) - 158-0405



Upgraded Cleaner Mixing System

Complete Cleaner Tank Assembly - 164-8043
Complete Water Tank Assembly - 164-8041
Cleaner Pump Assembly for Concentrate
 164-8027
Cleaner Tubing #14 for Super Concentrate
 164-8025

Cleaner Tubing #16 for Regular Concentrate
 164-8026
Supply Tank Cap
 164-8081
Supply Tank Gasket
 164-0021

Cleaning

- Complete Cleaner Tank Assembly - 164-8042 - FXW | FLX**
- Complete Supply Tank Assembly - 154-8840 - XF | KK | PX-C**
- Complete Cleaner Tank Assembly - 158-8433C - IKN | KW | ION-B,C,D | KP-B**
- Complete Cleaner Supply Tank Assembly - 154-8894 - ION-A | KP-A**
- Cleaner Supply Tank Only - 158-8433 - KW | ION-B,C,D | KP-B**
- Cleaner Supply Tank Float Switch - 154-8693**



- Cushion Roller With Cloth Cover - 164-8839**
Compatible with IKN | FXW | FLX | KW | ION | XF | KP
Use same part number to upgrade these models: **KK**
If ordering to upgrade KK you will need (2)
153-6421S spacers and hardware (153-2069).

Cushion Roller - 153-8838 - KK

PVC Take-Up Reel - 153-8824

(Not required with K2/K3 Select Cloth)

PVC Take-Up Reel Clamp - 154-6248 (Not Pictured)

Complete Squeegee Assembly (Blue) - 153-0202D

(Includes inside and outside channel)

KW | ION | XF | KP | KK

Replacement Squeegee Blades & Gasket Kit - 164-8038K

IKN | FXW | FLX (also for machines with upgraded Squeegee Cartridge)

Squeegee Gasket - 164-0003 - IKN | FLX | FXW



Replacement Squeegee Blades - Blue Pair - 153-8204E

Replacement Squeegee Blades - Brown Pair - 153-8834



Vacuum Motor - See Motors on pages 28 & 30

Following Items are Not Pictured

Vacuum Housing - 153-0204H

Fan Blade - 153-0204F

Flexible Hose (Sold by the Inch) - 154-0260

Cleaner Tip Check Valve (Pkg of 5)

154-0862K - KW | ION | KP

Cleaner Tip with Check Valve

164-0012M



Male Luer

1/8" Hose Barb - 154-0863



Sprayless Cleaner Pumps



- Cleaner Pump Drive Motor
- 154-8874 (115VAC)
- 154-8875 (230VAC)
- 158-8404 (24VDC)
- Cleaner Pump Assembly - 158-8404D
- Norprene® Tubing - 154-0861B
- Cleaner Volume Control Valve - 154-1855
- Cleaner Tip & Hose Assembly - 154-8852

Potentiometer for Cleaner Control

- 154-8846 - KP
- 158-8413 - KW | ION

Complete Cleaner Pump Assembly

- 154-8859 (115VAC) - KP-A
- 154-8859E (230VAC) - KP-A

Complete Cleaner Pump Assembly

- 158-8404C (24VDC) - KW | ION-A,B
- 154-8847 (24VDC) - KP-B

Solenoid Valve (3-Way)

- 154-8876A (115VAC) - KP-A Only
- 154-1852 (230VAC) - KP-A Only

Kustodian PLUS (Model A Only) 24VDC Cleaner Pump Conversion Kit

- 154-8844 (115V)
- 154-8845 (230V)



- Cleaner Tank Filter - 154-0212B
- 1/2" O-Ring - 154-0287C

Cleaner Funnels

- Cleaner Funnel - Long Stem
- 158-8252
- Cleaner Funnel - Short Stem
- 154-8647
- Cleaner Funnel - No Stem
- 153-0252



Spray Jet Cleaner Pumps

- Kegel Cleaner Spray Pumps
- 158-8212 (115V AC)
- 158-8213 (230V AC)



Cleaner Pump Repair Kit

- Valve/Diaphragm Kit for Kegel Pump
- 158-8212K

Spray Jet Assembly

- Tip Retainer - 153-0218
- Spray Jet Body - 153-6252
- Nylon Body - 153-0217



Screen Check Valve - 153-0220

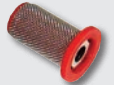

- Outside Spray Tip (1501) - 154-0007
- Inside Spray Tip (8003) - 153-0207
- Inside Spray Tip (11003) - 153-0207A



- Universal In-Line Filter Assembly - 154-8867A
- In-Line Filter Assembly - 154-8887 - IKN | KW | ION | KP

Cleaning System Tubing

- (Sold by the Inch)
- 1/4" - 153-0208S - for Spray Jet Machines
- 1/4" - 154-0202C - Clear

LEGEND

SUFFIX	MACHINE	SUFFIX	MACHINE
IKN	IKON	ION	KUSTODIAN ION
FWYEAR*	FLEX WALKER YEAR	XF	CROSSFIRE
FXYEAR*	FLEX YEAR	KP	KUSTODIAN PLUS
FXW	FLEX WALKER 2013-15	KK	KUSTODIAN
FLX	FLEX 2013-15	PX-C	PHOENIX C
KW	KUSTODIAN WALKER		

Some models on the list have been discontinued, making some parts unavailable. Models include Elite (ELT), Standard (STD), Elite Plus (EP), Phoenix (PX), Phoenix-S (PXS)

* YEAR represents the model year in the serial number. Suffix represents all model variations unless model type is specifically indicated (i.e. KP-A).

Conditioning

FLEX Conditioner Cartridge

(Complete with Valve Assembly) - 164-8015 (Pkg of 2)

FLEX Conditioner Cartridge

(Without Valve Assembly) - 164-8015A

Cartridge Plunger - 164-8015P

Cartridge Cap (with 38mm hole)

164-0004

Viton O-Ring for Cap

Viton O-Ring for Plunger (outside)

164-6079

Cable Carrier for Oil Head Assembly

164-9009- FW | FX

FLEX Conditioner Sub Tanks

164-6015A - 164-6015B

FLEX Conditioner Sub Tank Float Switch

154-8693

FLEX Conditioner Sub Tank Filter Assembly

154-0212

Sub Tank O-Ring

164-6173

Sub Tank Replacement Plug

164-8082

Sub Tank Upgrade Kit

164-8215

Inline Filter Assembly

164-0215



Conditioner Transfer System

Single Conditioner Transfer Brush Assembly - 164-0866



Conditioner Transfer Brush Assembly - 154-0866 - KW | ION | KP

Buffer Brush - 154-8641 - KW | ION | XF | KP | KK | PX-C

(Upgraded Transfer Brush to DUO System)

Buffer Brush - 164-8001 - FXW | FLX

Buffer Brush - 164-8001A - IKN | FW | FX

Transfer Roller - 154-8338 - PX-C

Transfer Roller - 154-8608 - KK

Transfer Roller - 158-8204 - XF

Transfer Roller - 164-8008 - IKN | ALL FLEX

Transfer Roller Duo Upgrade - 158-8441

Transfer Roller Belt Duo System 100XL037 - 154-9203 - IKN | ALL FLEX

Buffer Belt 315L050 - 164-9019 - IKN

Buffer Belt 255L050 - 154-9615 - ION-A,B | KP | KK

Buffer Belt 225L050 - 153-9817 - PX-C

Buffer Belt 210L050 - 158-9201 - XF

Buffer Belt 263L050 - 158-9026 - KW | ION-D

Buffer Belt Standard 248L050 - 164-9006 - FXW | FLX

Buffer Belt for Variable Speed Upgrade 255L050- 154-9615 - FXW | FLX (FLX-17733 / FXW-13229 and ABOVE)

Buffer Belt for Variable Speed Upgrade 248L050- 164-9006 - FXW | FLX (FLX-17732 / FXW-13228 and BELOW)

Buffer Belt for Non-Variable Buffer 352L050 - 164-9016 - FW | FX

Buffer Belt for Variable Buffer 356L050 - 164-9017 - FW | FX



Head Drive Belt - 154-9201

Compatible with ALL applications.

Fluid Metering Components

1. Pulse Suppression Assembly

164-8021 - FXW | FLX

154-8660 - EP | ELT | STD | PXS-C

154-8816 - IKN | KW | ION | KP | KK

2. Pressure Gauge (60 psi) - 158-1613

3. Oil Control Valve (24V DC) - 154-1209

Oil Control Valve (24V DC - Extended Wires & Fittings) - 154-8298

4. Vent Valve

154-8817 - IKN | KW | ION | KP

164-8007 - FXW | FLX

5. Oil Tank Assembly with Fittings/Float

154-8682 - IKN | KW | ION | KP

Oil Tank Assembly with Fittings

154-8842 - KK

6. Oil Tank Filter - 154-0212

7. Float Switch Assembly

154-1203 - XF

154-8693 - IKN | KW | ION | KP | PX-C

8. Belt for Conditioner Pump Motor

154-9202A (60Hz) 154-9215 (50Hz)

164-9008 - FXW | FLX

9. Oil Tank Cap Assembly

164-8081 - Complete

164-0021 - Gasket only

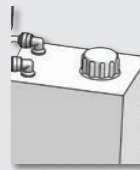
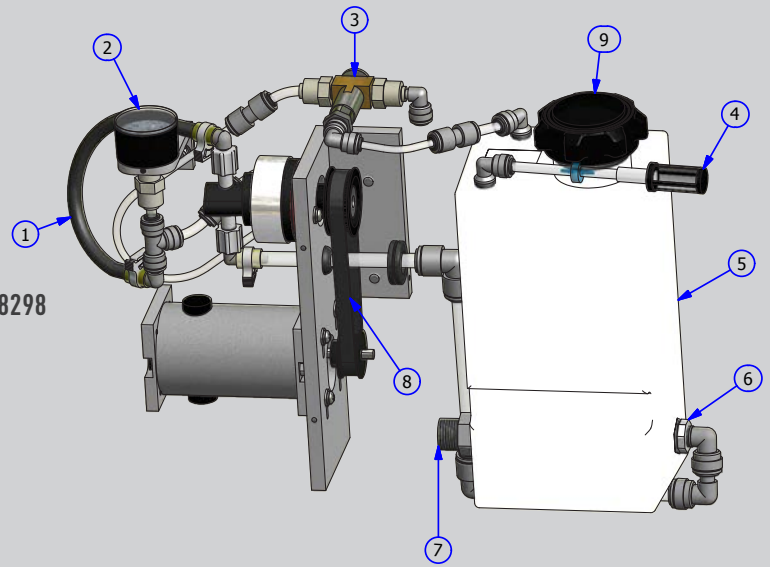

Oil Tank Cap Assembly

154-0832 - Complete

154-0832C - Cap only

154-0832G - Gasket only

Tubing

Conditioning System Tubing

(Sold by the Inch)

3/16" - 154-0202B

1/4" - 154-0202A

3/8" - 154-0202

Conditioner Head Tip & Hose Holder Assembly (includes tubing)

3- 1/2" Tip Holder (Painted Machines with Transfer Roller) - 154-8883

4- 1/2" Tip Holder (Painted Machines with Transfer Brush) - 154-8851

5- 1/4" Tip Holder (Upgraded Transfer Brush Models) - 154-8896

Retaining Spring for Head - 153-2713

Oil Pencil Tip (Black Molded) - 154-6832

Graduated Cylinder (25ml) - 154-0215

Felt for Graduated Cylinder (25ml) - 154-0210

Graduated Cylinder (50ml) - 154-0215A

Felt for Graduated Cylinder (50ml) - 154-0210A

Replacement Felt

Felt (1/8" x 3") - (Sold by the Inch) - 154-0228S

Felt (1/8" x 9") - (Sold by the Inch) - 154-0628S

Felt Strip on Splash Guard Tank - 154-8333 - PX-C Only

Felt Kit for Transfer and Spray Jet Wall - 154-8669 - KK

Felt Strip for Transfer Wall - 154-8669A - KW | ION | KP

Felt Kit - 164-8212 - FXW | FLX

Oil Funnel with 3" Hose - 153-0052A

Fluid Metering Oil Pump

154-1214



PLC

PLC Components



CP1H PLC (w/o Ports) - 158-1610P
CP1L PLC (24VDC - w/o Ports) - 164-1228 - ION B | KW B
Serial Port Converter for CP1 - 158-1610S
Analog Output - 164-1217 - FXW | FLX
Communication Cable - 164-1235 - IKN | FW19, 20 | FX19, 20
Communication Cable - 158-1610D - FXW | FLX13-18
Communication Cable - 158-1610CC - KW C,D | ION C,D
Communication Cable CP1L PLC - 154-8809
CPM2A Keypad Cable - 154-1803
CP1L Keypad Cable - 154-8809
Replacement Battery CP1L - 158-1610B

Touchscreen Components



Touchscreen Display 7" - 164-8203 - FW19,20 | FX19,20
Touchscreen Protector 7" - 164-1245 - FW19,20 | FX19,20
Touchscreen Display 5" - 158-8671 - KW C,D | ION C,D
Touchscreen Display 5" - 164-8011 - FXW | FLX
Touchscreen Protector 5" - 158-1612 - FXW | FLX
Touchscreen Mounting Clip - 158-1610TC - FXW | FLX (set of 2)



Touchscreen Display - 164-8803 - IKN
Touchscreen Protector - 164-1234 - IKN

Replacement PLC Kits*

CP1L PLC (115VAC - w/o Ports)*

164-1230 - KK | KP A,B | XF

*The Omron® CPM2A PLC is no longer available and has been replaced by the Omron® CP1L PLC. A replacement kit has been designed to make the necessary modification in the event a new PLC is needed.

DC Conversion Kit - 158-8454 - KW A,B | ION A,B

AC Conversion Kit* - 158-8254 - KK | KP A,B | XF-C | PX-C

Twido To CP1L Upgrade - 158-8253 - XF A,B

Additional upgrade kits may be necessary for KK A,B | KP A,B
Contact Kegel for more information.

154-8853C – Relay kit for Original Kustodian
(Version 9G and above) *If not already in machine this kit is needed for PLC upgrade

154-8853Z – Relay kit for Kustodian Plus
(Version 9Z and above) *If not already in machine this kit is needed for PLC upgrade

154-1801M - PX-C Expansion Module

Omron® PLC Battery

154-1804 - CPM2A

Keypad

154-8806 - ION | KP | KK

154-8806C - XF (Omron®)

154-8807 - PX-C

154-8808 - Firebird

Keypad Overlay Decal

158-0802 - KW-B

154-0801 - ION | KP | KK

154-0801K - XF (Omron®)

Keypad Mounting Clips

(set of 2)

154-1802C

LEGEND

SUFFIX	MACHINE	SUFFIX	MACHINE
IKN	IKON	ION	KUSTODIAN ION
FWYEAR*	FLEX WALKER YEAR	XF	CROSSFIRE
FXYEAR*	FLEX YEAR	KP	KUSTODIAN PLUS
FXW	FLEX WALKER 2013-15	KK	KUSTODIAN
FLX	FLEX 2013-15	PX-C	PHOENIX C
KW	KUSTODIAN WALKER		

Some models on the list have been discontinued, making some parts unavailable. Models include Elite (ELT), Standard (STD), Elite Plus (EP), Phoenix (PX), Phoenix-S (PXS)

* YEAR represents the model year in the serial number. Suffix represents all model variations unless model type is specifically indicated (i.e. KP-A).

KOSI Kegeel Online Support Interface



KOSI Pro Kit - 154-8781 - IKN | FXW | FLX
 USB to Serial Converter
 KOSI Cable (32 or 64 bit)
 USB Drive with KOSI Pro Software



KOSI Pro Kit for Kustodian - 154-8771
 USB to Serial Converter
 KOSI Cable (32 or 64 bit)
 USB Drive with KOSI Pro Software



Wi-Fi Connectivity Kit - 164-8821A
 IKN | FXW19,20 | FLX19,20
Wi-Fi Connectivity Kit - 164-8821B
 FXW13 to 18 | FLX13 to 18

Wi-Fi Replacement Device - 164-8820A
 IKN | FXW | FLX

KOSI Communication Kit - 154-8771B
 USB to Serial Converter
 KOSI Cable (32 or 64 bit)



USB to Serial Converter
 157-1057



KOSI Cable
 (32 or 64 bit) - 154-8724

Batteries & Chargers

Kegel K2 Energy® Lithium Batteries



158-1634 (25.6 Ah)



158-1634B (38.4 Ah)



158-1634C (51.2 Ah)

Batteries				
Machine Type	Lanes Per Charge	KEGEL Charger Being Used	Battery Available	Kit Needed
ION-A,B	Up to 40	ProTech	158-1634	158-8654
	Up to 62	Any	158-1634B	158-8654
KW-A,B	Up to 40	ProTech/ProNautic	158-1634	158-8655
	Up to 62	Any	158-1634B	158-8655
KW ION-C,D	Up to 40	ProTech/ProNautic	158-1634	158-8655
	Up to 62	Any	158-1634B	158-8655
	Up to 90	Any	158-1634C	158-8655
IKN FXW FLX	Up to 40	ProNautic	158-1634	None
	Up to 62	ProNautic	158-1634B	None
	Up to 90	ProNautic	158-1634C	None



ProNautic®
Chargers

ProNautic® Chargers		
Machine Type	115V	230V
ION-A,B	158-8476	158-8476E
ION-C,D	164-8471P	164-8471PE
FXW FLX IKN KW	164-8471	164-8471E

*This is a kit that includes the ProNautic® Charger along with the necessary hardware to convert your machine to an external charging unit as the internal unit is no longer available.

Charger DC Cables	Description
158-8474	ProTech DC power cord assembly - 1 FT Internal
158-8475	ProTech DC power cord assembly - 6 FT External
164-8475	ProNautic DC power cord assembly - 6 FT External

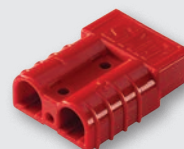

Battery Disconnect Housing - Red
158-1407 (1 ea.)



Battery Disconnect Housing - Blue
158-1408 (1 ea.)



6 ga. Terminal - 158-1407A
10 ga. Terminal - 158-1407T

CVR Replacement Kit (2016 FLEX and later)
164-8210

CVR Replacement Kit (KW and ION)
164-8083

Converted DC to DC Step Up Assembly - CVR
(FX18-121 / FW18-182 and later)
164-8209

CVRs for all ION and WALKER models
contact Kegel.

The disconnect housings automatically come with terminals for 10 ga. wire. If your lane machine has 6 ga. wire, order the 6 ga. terminals in addition to the housing.

Electrical Components

Power Cord Components

Description	115V AC	230V AC
Power Cord ION XF KP KK PX-C	154-8829	154-8830
Male Plug End (15A)	153-1025	153-1625
Male Plug End (20A)	153-1825	N/A
Female Twistlock Plug (15A)	153-1024	153-1624
Female Twistlock Plug (20A)	153-1822	153-1824
25' Charging Cord Assembly KW ION-A,B	158-8425	158-8425E
Velcro Strap For Cord	154-0242	154-0242

Push Button Replacements

Handle Button Replacement Assembly - 164-8013 - IKN | FLX

Handle Wire without Connector - 153-8424A - XF

Handle Wire - 154-8893B - ION | KP

Handle Button Replacement Assembly - 154-8824 - KK

Power Up/Cleaner Test Button - 158-8439

IKN | ALL FLEX | KW C-D | ION C-D

Head Motor 6.0 μ F Capacitor

154-1208 - KP | KK

Oil Pump Motor 1.5 μ F Capacitor

154-1208B - KP | KK

Breakers



Rocker Breaker 10A - 154-1272

Rocker Breaker 15A - 154-1610

Blade Type Fuses

Fuse 25A - 158-1439 for CVR - KW | ION

Fuse 30A - 164-1214 for CVR on VB Upgrade and

Pro Nautic[®] Charger - IKN | FXW | FLX

Fuse 40A - 158-1440 for IOTA[®] Battery Chargers

Maxi-Fuse 40A (for Fuse Link) - 158-1454 - ION

Fuse Link Assembly - 158-8421 - ION

Clear Cover for Electrical Panel

164-6183 - FW13 to 18 | FX13 to 18

164-6062 - FW19,20 | FX19,20

164-6815 - IKN

Replacement LED Light Kits

FLEX Arrow Light - 164-8079

FLEX Tank Light - 164-8024

Fuse & Relay Kit



With these kits, you will have many of the small electronic pieces needed to keep you going. These kits contain three of each fuse used in the machine as well as fuse holders, spare relays, buttons, and switches.

154-8800F (115V)- KK-A,B

154-8800G (230V) - KK-A,B

154-8800J (115V)- KK-C

154-8800K (230V) - KK-C

154-8800R (115V) - KP

154-8800S (230V) - KP

154-8800C (115V) - XF

154-8800D (230V) - XF

158-8600F - KW-A,B | ION-A,B

158-8600G - KW-C,D | ION-C,D

164-8100F - FXW | FLX

164-8800F - IKN

Fuses

Panel Mount Fuse Holder (115V) - 153-1028

Fuse 0.5A (UL) - 154-1261

Fuse 0.75A (UL) - 154-1262

Fuse 1A (MDL) Ceramic - 155-1229C

Fuse 1.8A (UL) - 154-1265

Fuse 2.25A (UL) - 154-1266

Fuse 3.2A (UL) - 154-1267

Fuse 4A (UL) Ceramic - 154-1268C

Fuse 7.5A (UL) - 154-1270

Fuse 8A (UL) Ceramic - 154-1270C

Fuse 10A (UL) - 154-1273

Fuse 20A (UL) Ceramic - 154-1274C

Fuse 20A (UL) - 154-1274

Fuse 25A (MDA) Ceramic - 164-1222

Panel Mount Fuse Holder (230V) - 153-1028E

Fuse 315mA (IEC - 230V) - 154-1260E

Fuse 500mA (IEC - 230V) - 154-1261E

Fuse 1A (IEC - 230V) - 154-1264E

Fuse 1.6A (IEC - 230V) - 154-1265E

Fuse 4A (IEC - 230V) - 154-1267E

Fuse 6.3A (IEC - 230V) Ceramic - 154-1269C

Electrical Components

Omron® Brand Relays



LY2 Relay
153-1016D (24V DC Coil)
LY2 Relay
153-1016 (115V)
153-1616 (230V)



LY3 Relay
153-1018 (115V)
153-1618 (230V)



LY4 Relay
153-1406 (115V)
154-1611 (230V)



MY4 Relay
(24V DC)
158-1427

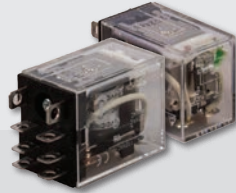

DPDT 10A
158-1462



PLC Output Relay (Short)
153-1032 (for Output Module OC221/OC222)
PLC Output Relay (Tall)
154-1215 (24V DC Coil - for Output Module OC222 only)

Omron® Relays for Sport Edition / FLEX / IKON Models



24VDC DPDT
158-1458



Solid State
158-1460



Super MY4 24V DC
(with Diode)
158-1463



LY3 Relay
(24V DC)
164-1231

Phoenix® Brand Relays



Secondary Relay Assembly
(24V DC)
154-1835 - KP | KK



2 Pole Relay
(10A - 24V DC)
158-1420G

Automation Direct® Relays



2 Pole Relay
(15A - 24V DC)
158-1413

Other Electrical Components



Duster Microswitch
(Large) 154-1603
IKN | FXW | FLX | KW | ION |
KP | KK | PX-C



Duster Microswitch
(Small) 153-1202
XF | PXS-A,B | PX-A,B



**Microswitch
with Roller**
153-1203
for ALL Machines



Squeegee Microswitch
(Large) 154-1015
PX-C



Arc Suppressor
158-1438

15K Resistor
(for cleaner speed control)
154-8848R



Proximity Sensor
154-1220

Proximity Sensor
158-1208 - XF-A



Contactor 24VDC
158-1465 - IKN | FXW | FLX
KW C,D | ION C,D
(Vacuum & Auto Shutdown
Relay)



Red Push Button
(Normally Open)
153-1408



Horsepower Resistor
0.025 Ω - 153-1015A
Horsepower Resistor
0.050 Ω - 153-1015



E-Stop Assembly for FLEX/IKON - 164-1223
(Includes Breaker, Black Box sold separately)
E-Stop Black Box for FLEX/IKON - 164-6161
FLEX E-Stop Breaker - 164-1223B
Prior to serial #FLX-17802 / FXW-13306 use part number 164-1223
(This will replace the discontinued Breaker and red triangle
shaped e-stop assembly)



2008 E-Stop (2-Hole Pattern)
154-1250A
Breaker for E-Stop
(2008 and later)
154-1251A

VOLTMETER TIPS



VOLTMETER SYMBOLS



Alternating Current
V AC
All 115V and 230V machines
that utilize a power cord.



Direct Current
V DC
All battery operated
machines / also used to
drive AC powered machines.



Continuity Check
Used to inspect fuses and
circuitry. A beep will sound
when fuse or circuit is
closed.

BASIC VOLTMETER OPERATIONS

To check voltage:

1. Turn dial on the voltmeter to desired test.
2. Place each probe into the wires of the component you are testing and turn component on.

To check continuity:

1. Touch both probes together to inspect the voltmeter for proper function.
2. Place the test probes at each end of the circuit to be tested.
3. Voltmeter will sound if circuit is not broken. No sound if there is a break in the line.

TECH TIP:

Always inspect power cord ends and battery connections when electrical problems occur.

Upgrades

DUO™ Transfer System

Transfer Brush System to DUO System
158-8430F

Smoother Pad Transfer System to DUO System
158-8430N - Only painted machines with transfer roller



Complete Squeegee Cartridge Assembly
164-8038

Handle Mount Kit
164-8253- IKN | FLX

Handle Reinforcement Kit
154-8284 - ION A,B | KP | KK

Crossfire Upgrades

Complete Upgrade - Includes 8 Wicks with Cam Roller and Large Conditioner Supply Tank
158-8241 (115V) | 158-8241E (230V)

Conditioner Tank Upgrade
158-8215 (115V) | 158-8215E (230V)

8 Pad Wick & Cam Kit - 158-8214



Fail Safe Beam - 164-8827 - FXW | FLX

Pin Deck Treatment Upgrade
164-8227 - FXW | FLX
164-8202 - FW19 | FX19

Pin Deck Treatment Tip Cover
164-2067

LED Light Upgrade Kit for Supply Tanks

Easily monitor the level of supplies on machines with plastic molded tanks with this light that automatically illuminates when the splash guard is opened.
158-8672 KW | ION | KP-A,B

Kustodian Upgrades

Head Relay Upgrade Kit
154-8853C - KK-C

Drop Brush Upgrade Kit
154-8853Z - KP

Kustodian Model A to C Upgrade Kit - 154-8870
Serial Number: KK-0600 through KK-0810

Kustodian Model B to C Upgrade Kit - 154-8871
Serial Number: KK-0811 through KK-0987

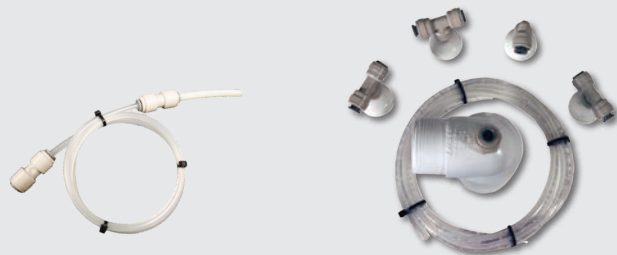

Spray Pressure Regulator Upgrade
154-8268

Spray Jet Cup Assembly Upgrade
154-8692

Duster Plug Stud Kit (Set)
164-8817

Cushion Roller Arm Stud Kit (Set)
164-8822

Wheel Upgrades



6" Front Wheel Upgrade

Large 6" front wheel helps the lane machine transition on and off the lane with ease.
158-8733 ION | KP-B

3" Caster Upgrade

Dual 3" rear casters allow for better machine transition on and off the lane.
158-8731 KW | ION-C,D
158-8732 ION-A,B | KP-B

Miscellaneous

Non-Adjustable Guide Rollers

Guide Roller - 153-8410
Guide Roller Shoulder Bolt - 153-2407
Guide Roller Mounting Bar - 153-6417
Guide Roller Spring - 153-2401
SHCS ¼-20 x 2-¾" - 153-2211

Adjustable Guide Rollers



Complete Front Assembly - 158-8643
Complete Rear Assembly - 158-8642
Front Wheel Only - 158-8637
Rear Wheel Only - 158-8636

Complete Rear Assembly Black - 164-8816 - IKN
Rear Wheel Only Black - 164-8815
Compression Spring - 153-2978

Tune Up Kits



IKN - 164-8800
FW16 and up | FX16 and up - 164-8030A
FW13 to 15 | FX13 to 15 - 164-8030
KW - 158-8628
ION - 158-8428
KP | (115V) - 154-8686
KP | (230V) - 154-8687
KK | PX-C (115V) - 154-8888
XF (115V) - 158-8288
XF (230V) - 158-8288E

Momentary Wheel Assembly



Wheel - 153-7005R
Shaft - 153-6006
Housing - 153-6029

Caster Wheels

Lane to Lane Caster 2"
153-0812 (Heavy Duty)
Lane to Lane Caster 3"



164-0022 - IKN | FLX - 2016 or later



Transport Caster
3" Dual Wheel (Black) - 153-0001BK
3" Dual Wheel (Gray) - 153-0001
2" Single Wheel - 153-0002

Whiskers

Whisker Spring - 153-2946 - KW
Black Vinyl Cap - 153-2941 - KW
Complete Assembly - 158-8623 - KW
Whisker Assembly - 164-8660 - FXW
Whisker Assembly - 164-8660A - FW



FLEX Whisker Upgrade
Complete Set - 164-8826 - FXW | KW
Left Whisker - 164-8824 - FXW | KW
Right Whisker - 164-8825 - FXW | KW
Left & Right Whisker only - 158-8624 - FXW | KW

Motors & Speed Controls

Sanction Technology™

COMPONENTS	IKN	FLX	FXW	KW-C,D ION-C,D	KW-A,B ION-A,B	KK KP
Buffer Motor (115V AC)	N/A	N/A	N/A	N/A	N/A	154-8616A
Buffer Motor (230V AC)	N/A	N/A	N/A	N/A	N/A	154-8616E
Buffer Motor (24V DC) - Standard	158-8414	158-8414	158-8414	158-8414	158-8414	N/A
Buffer Motor (24V DC) - Variable Speed Upgrade	N/A	164-8014A	164-8014A	N/A	N/A	N/A
Buffer Motor Brushes (24V DC)	158-1406B	158-1406B	158-1406B	158-1406B	158-1406B	N/A
Buffer Motor Contactor (115V AC)	N/A	N/A	N/A	N/A	N/A	153-1004A
Buffer Motor Contactor (230V AC)	N/A	N/A	N/A	N/A	N/A	153-1604A
Conditioner Pump Motor (115V AC)	N/A	N/A	N/A	N/A	N/A	154-8604
Conditioner Pump Motor (230V AC)	N/A	N/A	N/A	N/A	N/A	154-8604E
Conditioner Pump Motor (24V DC)	158-8401A	158-8632	158-8632	158-8632	158-8401A	N/A
Conditioner Pump Motor Brushes (24V DC) BISON	N/A	N/A	N/A	N/A	158-1422B	N/A
Conditioner Pump Motor Brushes (24V DC) Groschopp®	158-1422G	N/A	N/A	N/A	158-1422G	N/A
Drive Motor (90V DC) replacing Groschopp®	N/A	N/A	N/A	N/A	158-8260	154-8865
Drive Motor (90V DC) replacing Baldor®	N/A	N/A	N/A	N/A	158-8260K	N/A
Drive Motor (24V DC)	158-8406	N/A	N/A	N/A	158-8406 - ION	N/A
Drive Motor (24V DC) 3" Shaft *	N/A	164-8602* FX13,14,15	164-8602 ZTR* FW16 and up	164-8602 ZTR*	164-8602* KW	N/A
Main Drive Motor (24V DC) 4.75" Shaft **	N/A	164-8602A** FX16 and up	164-8602A** FW16 and up	N/A	N/A	N/A
Duster Motor (115V AC)	N/A	N/A	N/A	N/A	N/A	153-8403
Duster Motor (230V AC)	N/A	N/A	N/A	N/A	N/A	153-8803H
Duster Motor (24V DC)	158-8403	158-8403	158-8403	158-8403	158-8403	N/A
Head Drive Motor (115V AC)	N/A	N/A	N/A	N/A	N/A	154-8232
Head Drive Motor (230V AC)	N/A	N/A	N/A	N/A	N/A	154-8632
Head Drive Motor (24V DC)	158-8405	164-8032	164-8032	158-8632	158-8405	N/A
Head Drive Motor Brushes (24V DC)	158-1404B	N/A	N/A	N/A	158-1404B	N/A
Squeegee & Brush Lift Motor (115V AC)	N/A	N/A	N/A	N/A	N/A	153-8207
Squeegee & Brush Lift Motor (230V AC)	N/A	N/A	N/A	N/A	N/A	153-8807H
Squeegee & Brush Lift Motor (24V DC)	158-8402	158-8402	158-8402	158-8402	158-8402	N/A
Vacuum Motor (115V AC)	N/A	N/A	N/A	N/A	N/A	154-8805
Vacuum Motor Brushes (115V AC Pair)	N/A	N/A	N/A	N/A	N/A	153-0204B
Vacuum Motor (230V AC)	N/A	N/A	N/A	N/A	N/A	154-8805E
Vacuum Motor Brushes (230V AC Pair)	N/A	N/A	N/A	N/A	N/A	153-0204C
Vacuum Motor (24V DC)	158-8407	158-8407	158-8407	158-8407	158-8407	N/A
Vacuum Brushes (24V DC Pair)	158-1421B	158-1421B	158-1421B	158-1421B	158-1421B	N/A

* When replacing a Baldor® motor you will need kit 164-8251

** When replacing a Baldor® motor you will need kit 164-8250

Please contact Kegel with any questions.

COMPONENTS	IKN	FLX	FXW	KW-C,D ION-C,D	KW-A,B ION-A,B	KK KP
Circuit Board w/Speed Relays (115V AC)	N/A	N/A	N/A	N/A	N/A	154-8810
Circuit Board w/Speed Relays (230V AC)	N/A	N/A	N/A	N/A	N/A	154-8811
Circuit Board w/Speed Relays (24V DC)	N/A	N/A	N/A	N/A	158-8409	N/A
Speed Control Assembly (24V DC-Buffer)	N/A	164-8225 FX	164-8225 FW	N/A	N/A	N/A
Speed Control Assembly (24V DC-Drive)	164-8807	164-8828	164-8828	164-1242A	158-8412	N/A
Speed Control Assembly (24V DC-Cleaner Pump)	164-8806	164-8221	164-8221 FW16,17,18	158-8415	158-8415	154-8848 KP
Speed Control Assembly (Oil/Cleaner Head)	N/A	158-1605	158-1605	158-1605	N/A	N/A
Speed Control Board Only (115V AC)	N/A	N/A	N/A	N/A	N/A	153-1012
Speed Control Board Only (230V AC)	N/A	N/A	N/A	N/A	N/A	153-1812
Speed Control Board Only (24V DC)	N/A	164-1242A	164-1242A	164-1242A	158-1410	N/A

For Dayton® Drive Motor - 153-8065
Rear Seal - 153-1057R
Front Seal (Shaft Side) - 153-1057S
Gasket - 153-1057F
Drive Motor Brushes (90V DC Pair) - 153-1057H

For ALL Baldor® Drive Motors
Rear Seal - 154-1809D
Front Seal (Shaft Side) - 154-1809E
Drive Motor Brushes (24V DC Pair) - 158-1405B
Drive Motor Brushes (90V DC Pair) - 154-1809B

WHAT IS NEW IN SPECTO BOWLING?



WORLDS

A guided game-like practice to help a player develop their skills. Just select the difficulty level and start with the first world. Improve your game while completing the missions

PERFORMANCE

Everything you need for a hard core practice. Learn about your ball reaction, accuracy, and see data related to your performance.

Challenges

Try different challenges to see how you stack up. Compete with bowlers in your center, country, and the world to get your name on the leader boards!



CHECK OUT THE BUSINESS MODELS and FINANCIAL PLANS AT
www.spectobowling.com

Motors & Speed Controls

Wick-Pad Technology

COMPONENTS	XF	PX-C
Buffer Motor (115V AC)	154-8616A	154-8616A
Buffer Motor (230V AC)	154-8616E	154-8616E
Buffer Motor Contactor (115V AC)	153-1004A	153-1004A
Buffer Motor Contactor (230V AC)	153-1604A	153-1604A
Drive Motor (90V DC)	154-8865	154-8865
Duster Motor (115V AC)	153-8403	153-8403
Duster Motor (230V AC)	153-8803 H	153-8803H
Squeegee & Brush Lift Motor (115V AC)	153-8207	153-8207
Squeegee & Brush Lift Motor (230V AC)	153-8807	153-8807H
Transfer Roller Motor (115V AC)	153-8828	154-8332
Transfer Roller Motor (230V AC)	153-8829	154-8332E
Vacuum Motor (115V AC)	158-8208	154-8805
Vacuum Motor Brushes (115V AC Pair)	153-0204B	153-0204B
Vacuum Motor (230V AC)	158-8208E	154-8805E
Vacuum Motor Brushes (230V AC Pair)	153-0204C	153-0204C
Circuit Board w/Speed Relays (115V AC)	N/A	154-8330
Circuit Board w/Speed Relays (230V AC)	N/A	154-8331
Speed Control Assembly (115/230V AC 3-Speed)	158-8211	N/A
Speed Control Board Only (115V AC)	158-1212R	153-1012
Speed Control Board Only (230V AC)	158-1212R	153-1812

Wicks



Glueless Wick Plate Assembly

3.125" - 153-8123 Only Compatible with PX-C
 3.125" - 158-8223 Only Compatible with XF



5.125" - 153-8125 Only Compatible with PX-C
 5.125" - 158-8225 Only Compatible with XF

7.125" - 153-8127 Only Compatible with PX-C
 7.125" - 158-8227 Only Compatible with XF

10.125" - 158-8230 Only Compatible with XF



Not Pictured
45" Wick Material for Glueless Wicks - 153-0005B (5")
Wick Material Stock for Glueless Wicks - 153-0005D - XF
 (Custom cut to be purchased by the inch)



Wick Spring (XF Only) - 153-2740

Solenoid Cable Assembly 8.25"
 153-8812A (PX-C)

Pattern Smoothing Pads

Pattern Smoothing Assembly - 154-8617
Velcro for Smoothing Pad
 154-8617V (10 per pack)
Smoothing Pad Spring
 153-2540A

Fittings



Elbow
1/4" Tube x 1/4" Tube - 154-0243



Elbow
3/8" x 3/8" - 154-0256



Elbow
3/8" NPT x 1/4" Tube - 154-0412
3/8" NPT x 3/8" Tube - 154-0803



Elbow
3/8" Tube x 1/4" NPT - 154-0225
1/4" Tube x 1/4" NPT - 154-0223



Elbow
1/4" Stem x 1/4" Hose Barb
154-0226



Elbow
1/4" Stem to 5/16" Hose Barb
154-0227



Elbow
3/8" Stem to 5/16" Hose Barb
154-0239



Elbow
3/8" Stem x 3/8" Tube - 154-0258
3/8" Stem x 1/4" Tube - 158-1214



Elbow
1/4" Stem x 1/4" Tube
154-0222



Elbow
1/8" NPT x 3/16" Tube
154-0613



Reducing Union
1/4" x 3/16" - 154-0248
3/8" to 1/4" - 154-0244



Bulkhead Union
3/8" x 3/8" - 154-0285
1/4" x 1/4" - 154-0221



Union
1/4" x 1/4" - 154-0241



Union Tee
1/4" Tube - 153-0815



Male Connector
1/4" Tube x 1/8" NPT - 154-0224
1/4" Tube x 1/4" NPTF - 154-0858
3/8" Tube x 1/4" NPT - 154-0814



Female Connector
1/4" Tube x 1/8" FPT - 154-0257



Union Tee
3/8" Tube - 154-0815

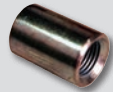

In-line Coupler
1/8" - 154-0230



Stem Adapter
1/4" NPT x 1/4" Stem
154-0243S



Male Connector
1/2" Tube x 1/2" NPT (Drilled)
154-0232D



Tank Plug
1/4" - 154-0245
3/8" - 153-1054
1/2" - 154-0231



O-Ring for Fitting
1/4" - 154-0287A
3/8" - 154-0287B
1/2" - 154-0287C

Lids & Guards

FLEX 2013-15 LID AND GUARD ACCESSORIES		
DESCRIPTION	COLOR	PART NUMBER
FLIP LID CLEANER SIDE	RED	164-8031F
FLIP LID CLEANER SIDE	BLACK	164-8033F
FLIP LID CLEANER SIDE	WHITE	164-8035F
FLIP LID CLEANER SIDE	BLUE	164-8037F
SLIDING LID CONDITIONER SIDE	RED	164-8031
SLIDING LID CONDITIONER SIDE	BLACK	164-8033
SLIDING LID CONDITIONER SIDE	WHITE	164-8035
SLIDING LID CONDITIONER SIDE	BLUE	164-8037
LEFT CABLE REEL ASSEMBLY	NA	164-8039
RIGHT CABLE REEL ASSEMBLY	NA	164-8040
LID PIVOT ARM PLATE ASSEMBLY	NA	164-8050A X2
PIVOT ARM RIGHT	NA	164-6100A
PIVOT ARM LEFT	NA	164-6101A

COLOR CODES	
BLUE	1525
BLACK	2850
RED	2911
WHITE	NO CODE

To order the correct color, place the color code number after the part number.



LID AND GUARD ACCESSORIES			
DESCRIPTION	FLEX 13-15	FLEX 16 AND UP	IKON
RIGHT GUARD UPPER	164-6732	164-6732	164-8811
LEFT GUARD UPPER	164-6733	164-6733	164-8812
RIGHT GUARD LOWER	164-8076	164-8235	164-8809
LEFT GUARD LOWER	164-8077	164-8234	164-8810
RIGHT GUARD WALKER	164-8074	164-8233	NA
LEFT GUARD WALKER	164-8075	164-8232	NA
FRONT BUMPER	164-8047	164-8236	164-8804
REAR PANEL	164-8049		164-8808
REAR PANEL WALKER	164-8048	164-8048	NA
SLIDING LID (HEAD)	NA	164-8230	164-8801
SLIDING LID (TAIL)	NA	164-8231	164-8802
LEFT LID TRACK	164-6119	164-6119A	164-6119A
RIGHT LID TRACK	164-6118	164-6118A	164-6118A
SHIM KIT	164-6170	164-6170	164-6170
REAR WALL (METAL)	164-6004-2850	164-6004A-2850	164-6004A-2850
SPRING CLIP	153-2125	164-2063	164-2063
SPRING CLIP SCREW	153-2124	153-2086	153-2086
FLAT WASHER	153-2002	153-2002	153-2002
LOCK WASHER	153-2013	153-2013	153-2013
FENDER WASHER	153-2953	153-2953	153-2953

FLEX LID STICKERS				
COLOR	HEAD	TAIL	FLE	X
WHITE	164-0014W	164-0015W	164-0008	164-0009
BLUE	164-0014B	164-0015B	164-0008	164-0009
PINK	164-0014P	164-0015P	164-0008	164-0009
RED	164-0014R	164-0015R	164-0008	164-0009
BLACK	164-0014	164-0015	164-0008	164-0009
GOLD	164-0014G	164-0015G	164-0008	164-0009
SILVER	164-0016	164-0017	164-0008	164-0009

IKON LID STICKERS			
HEAD	TAIL	ION	K
164-00140-714C	164-00150-714C	164-0024	164-00230-714C



Flush Mount Lid Latch
(Without Lock) - 153-2232A



Flush Mount Lid Latch
(With Lock) - 153-2232L



Push Latch with Key
154-0881



Flange Quarter Turn Lid Latch
154-0805



Straight Quarter Turn Lid Latch
(With Slot) - 154-0804

Hardware







HEX HEAD CAP SCREWS

1/4		5/16		3/8	
7/8"	153-2052	1"	153-2061	1"	153-2066
1"	153-2053	1 1/4"	153-2062	1 1/4"	153-2067
1 1/4"	153-2054			1 1/2"	153-5068
1 1/2"	153-2055			2"	153-2069







MACHINE SCREWS PHILLIPS

# 6		# 8		# 10	
1/2"	153-2081	5/8"	153-2086	3/4"	153-2091
7/8"	153-2083	3/8"	153-2086A	1"	153-2092
1"	153-2084	3/4"	153-2087		
1 1/4"	153-2085	1"	153-2089		
		1 1/2"	153-2090		

WASHERS

		FLAT	LOCK
	#6	153-2001	
	#8	153-2002	
	#10	153-2003	153-2013
	1/4	153-2004	153-2014
	5/16	153-2005	153-2015
	3/8	153-2006	153-2016

HEX NUTS

		STANDARD	NYLOK	JAM
	#6		153-2018	
	#8		153-2019	
	#10	153-2022	153-2208	153-2524
	1/4	153-2023	153-2020	153-2304
	5/16	153-2024	153-2735	5/16-18 153-2027A 5/16-24 153-2214
	3/8	153-2025	153-2021	153-2027
	1/2	153-2026		

**HAVE YOU
TRIED
PINSETTER PARTS
FROM KEGEL?**



MOLEX PLUGS



CONNECTOR	MALE	FEMALE
2 PIN	153-1041	153-1042
3 PIN	153-1044	153-1043
5 PIN	158-1206	158-1207
6 PIN	154-1231	154-1232
9 PIN	153-1039A	153-1040
12 PIN	153-1602A	153-1603
15 PIN	154-1807	154-1808
PINS	153-1046	153-1045
	Pin Removal Tool	153-4002

HIGH AMP CONNECTORS



	PLUG	PIN
MALE	153-1063	153-1065
FEMALE	153-1064	153-1066

Chains

CHAINS & ACCESSORIES

DESCRIPTION	FLEX 13-15	FLEX 16 AND UP	KW
MAIN DRIVE	154-9601 (40P41)	154-9601 (40P41)	158-9612 (40P43R)
LEFT SIDE ZTR	153-9814 (40P33)	153-9044A (40P29)	158-9609 (40P55R)
RIGHT SIDE ZTR	153-9444 (40P29)	164-9018 (40P23)	158-9609 (40P55R)
ZTR DRIVES ZTR WHEELS	164-9005 (35P97)	164-9005 (35P97)	NA
SMALL ZTR DRIVES 6 TOOTH STAR	164-9004 (25P55)	NA	158-9607
SECONDARY DRIVE	164-9010 (35p83)	NA	NA
SECONDARY DRIVE SPROCKET	164-9011	NA	NA

MAIN DRIVE CHAINS

MACHINE	PART #
IKON	154-9601 (40P41)
ION SPORT	158-9612 (40P43R)
ION B	158-9405 (40P45R)
KUSTODIAN PLUS	153-9814 (40P33)
KUSTODIAN	153-9814 (40P33)
CROSSFIRE	158-9203 (40P39)

MASTER LINKS

MASTER LINKS	PART #	OFFSET LINKS
#25	153-9045	NA
#35	153-9046	158-9022
#40	153-9047	153-9048

NO BOWLER LEFT BEHIND

Bowling's first lane conditioner
that adapts to a bowler's
playing style.



Terrain features shear-thinning chemical technology which responds differently to each individual bowler. The result is a single lane conditioner that is more forgiving for your center's wide range of bowlers.



PRODUCTS & PARTS

2019-20

www.kegel.net

Toll Free (US Only):
800 - 280 - BOWL (2695)
Fax: 863 - 734 - 0204
International: 863 - 734 - 0200

1951 Longleaf Boulevard
Lake Wales, FL 33859 USA